

# Overview: Module Physical Dimensions

| REVISIONS |          |        |                       |      |
|-----------|----------|--------|-----------------------|------|
| REV       | DATE     | ECN    | DESCRIPTION           | APVD |
| A         | 06/20/22 | 14160E | RELEASE TO PRODUCTION | JC   |

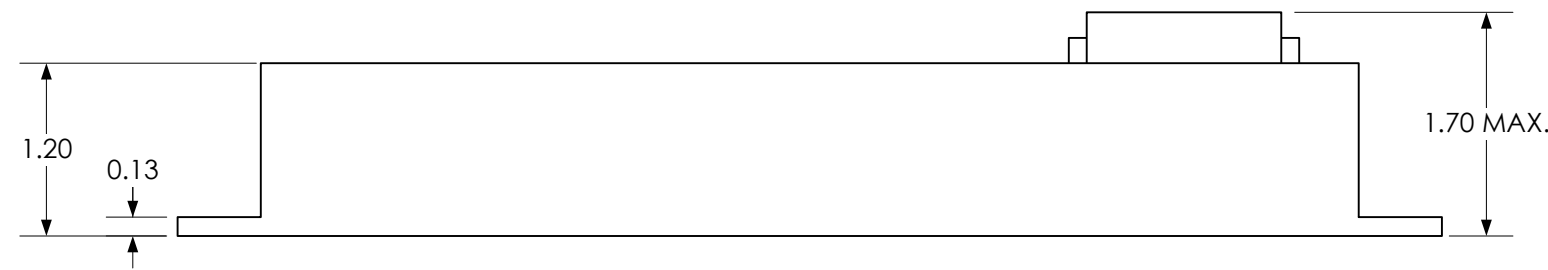
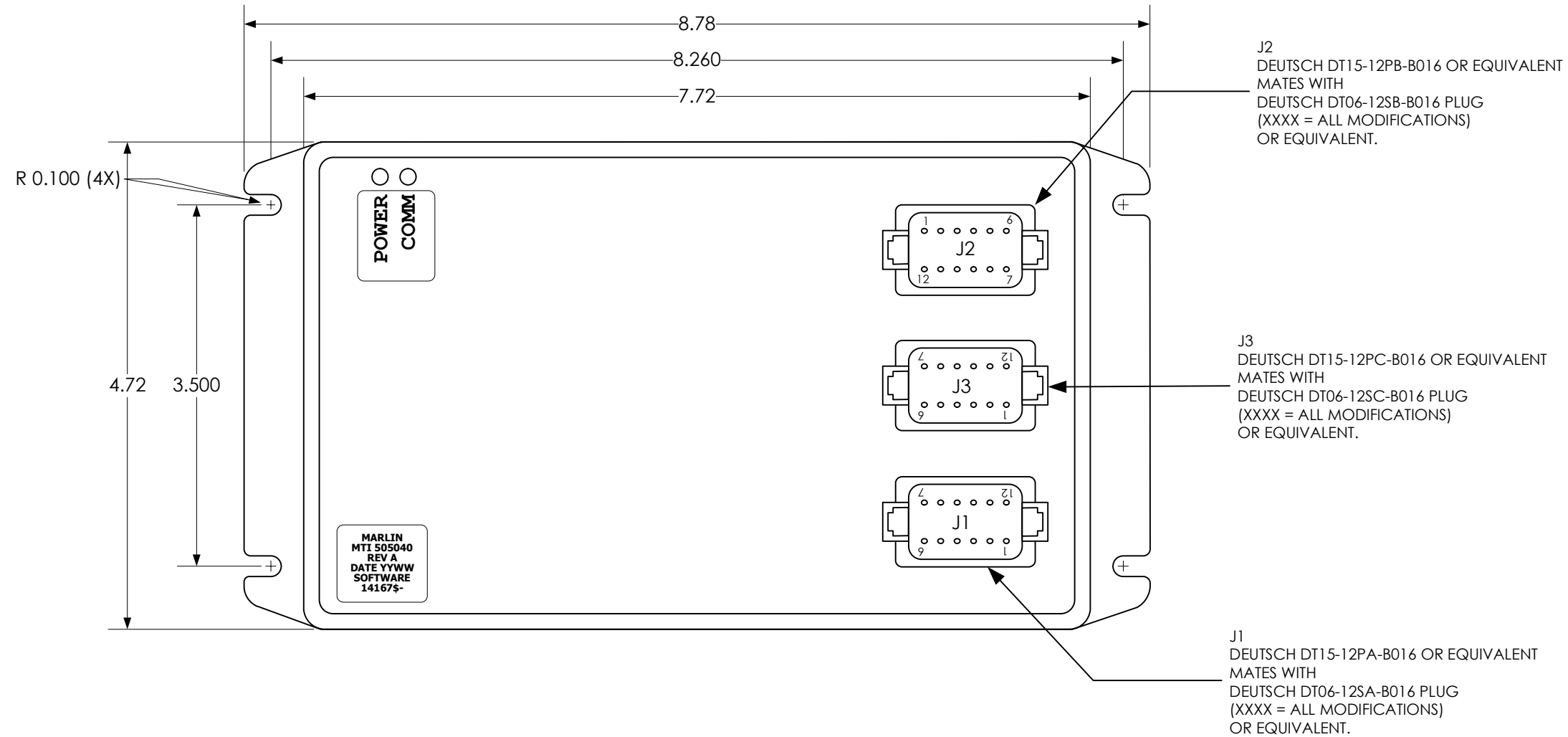

UNLESS OTHERWISE SPECIFIED, DIMENSIONS ARE IN INCHES AND TOLERANCES ARE

| TWO PLACE DECIMAL | THREE PLACE DECIMAL | ANGLES |
|-------------------|---------------------|--------|
| +/- 0.05          | +/- 0.020           | +/-    |

DO NOT SCALE DRAWING

|                    |                 |
|--------------------|-----------------|
| CHECKED J. COOPER  | DATE 06/30/2023 |
| APPROVED J. COOPER | DATE 06/30/2023 |

|   |                                 |                  |                 |
|---|---------------------------------|------------------|-----------------|
| <b>MARLIN</b> TECHNOLOGIES INC.                         |                                 |                  |                 |
| TITLE<br>OUTLINE, 505040<br>MFLEX HIGH CURRENT 8IN/8OUT |                                 |                  |                 |
| SIZE<br><b>B</b>  | DRAWING NUMBER<br><b>014162</b> | TYPE<br><b>O</b> | REV<br><b>A</b> |
| DRAWN M. PETZKE   |                                 | DATE 06/21/22    | SHEET 1 OF 3    |

THE INFORMATION CONTAINED ON THIS DRAWING IS PROPRIETARY AND CONFIDENTIAL TO MARLIN TECHNOLOGIES INC. UNAUTHORIZED USE OR DISTRIBUTION WITHOUT CONSENT IS PROHIBITED.

| REVISIONS |          |        |                       |      |
|-----------|----------|--------|-----------------------|------|
| REV       | DATE     | ECN    | DESCRIPTION           | APVD |
| A         | 06/20/22 | 14160E | RELEASE TO PRODUCTION | JC   |

# Overview: Module Block Diagram

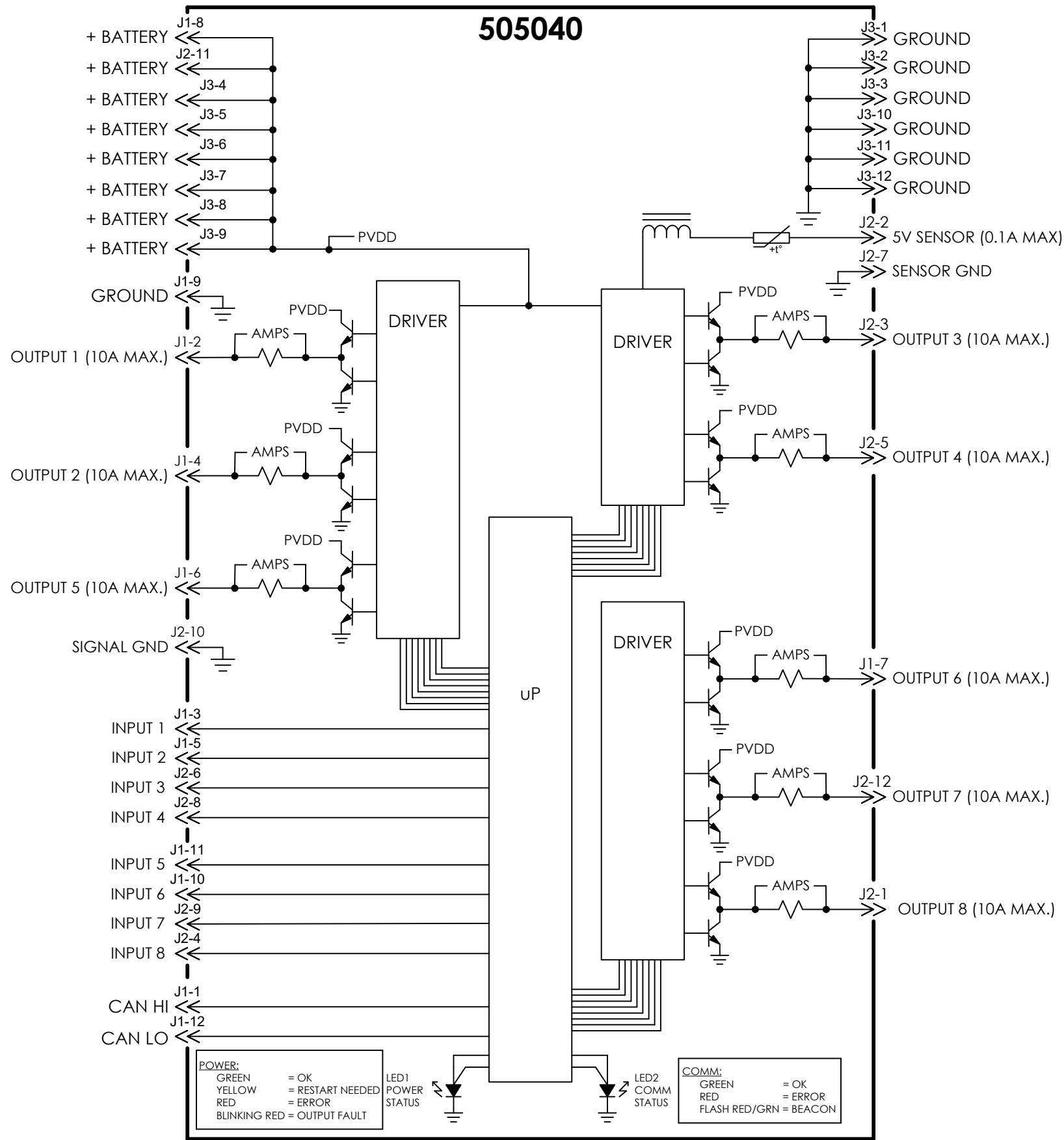

OPERATING VOLTAGE: 8 TO 36VDC (12VDC OR 24VDC NOMINAL)

**POWER:**  
 GREEN = OK  
 YELLOW = RESTART NEEDED  
 RED = ERROR  
 BLINKING RED = OUTPUT FAULT

LED1  
 POWER STATUS

LED2  
 COMM STATUS

**COMM:**  
 GREEN = OK  
 RED = ERROR  
 FLASH RED/GRN = BEACON

THE INFORMATION CONTAINED ON THIS DRAWING IS PROPRIETARY AND CONFIDENTIAL TO MARLIN TECHNOLOGIES INC. UNAUTHORIZED USE OR DISTRIBUTION WITHOUT CONSENT IS PROHIBITED.

|   |                                  |               |
|---|----------------------------------|---------------|
| UNLESS OTHERWISE SPECIFIED, DIMENSIONS ARE IN INCHES AND TOLERANCES ARE |                                  |               |
| TWO PLACE DECIMAL<br>+/- 0.05   | THREE PLACE DECIMAL<br>+/- 0.020 | ANGLES<br>+/- |
| DO NOT SCALE DRAWING  |                                  |               |
| CHECKED J. COOPER   | DATE 06/30/2023                  |               |
| APPROVED J. COOPER  | DATE 06/30/2023                  |               |

|   |                                 |                  |                 |
|---|---------------------------------|------------------|-----------------|
| <b>MARLIN</b> TECHNOLOGIES INC.                         |                                 |                  |                 |
| TITLE<br>OUTLINE, 505040<br>MFLEX HIGH CURRENT 8IN/8OUT |                                 |                  |                 |
| SIZE<br><b>B</b>  | DRAWING NUMBER<br><b>014162</b> | TYPE<br><b>O</b> | REV<br><b>A</b> |
| DRAWN M. PETZKE   |                                 | DATE 06/21/22    | SHEET 2 OF 3    |

# Overview: Input/Output Configurations

| REVISIONS |          |        |                       |      |
|-----------|----------|--------|-----------------------|------|
| REV       | DATE     | ECN    | DESCRIPTION           | APVD |
| A         | 06/20/22 | 14160E | RELEASE TO PRODUCTION | JC   |

## (\* NOTE: Analog Input Circuit and Best Practices)

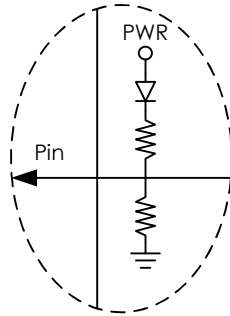

- Generated Analog Signal
- Analog Potentiometer (5k or less)
- On/Off Switch to Power (No Pull-Down)
- On/Off Switch to Gnd (No Pull-Up)
- 3-way Switch to Pwr/Gnd (No PU/PD)
- Frequency Input ( 0-5V, LS\_ Output )
- PWM Duty Cycle ( 0-5V, LS\_ Output )
- Quadrature Input ( 0-5V, LS\_ Output )

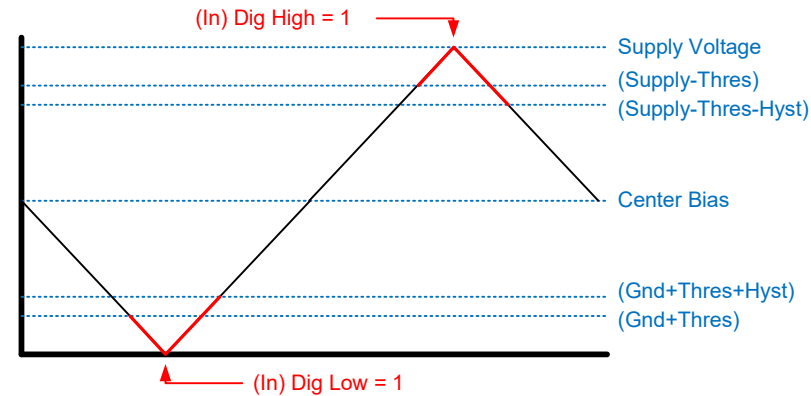

## (\* NOTE: Resistance Input Circuit and Best Practices)

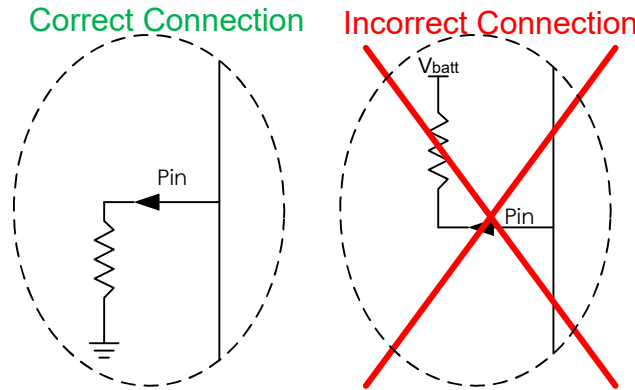

- An improper resistor connection is likely to damage the module.

## (\* NOTE: Current Input Circuit and Best Practices)

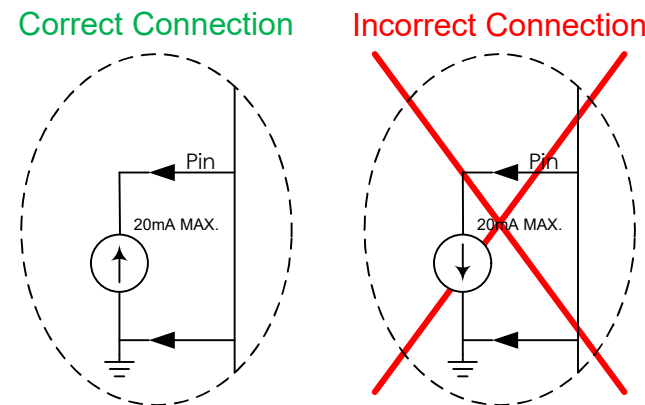

- Voltage on the input Pin must not exceed 6V when configured for current input.

- The input Pin when configured for current sensing is current sink and must be wired as such. Improper wiring can damage the module.

## Input/Output Configuration Options

| Input Type                  | #1 | #2 | #3 | #4 | #5 | #6 | #7 | #8 |
|-----------------------------|----|----|----|----|----|----|----|----|
| Digital Active High - Thres | •  | •  | •  | •  | •  | •  | •  | •  |
| Digital Active Low - Thres  | •  | •  | •  | •  | •  | •  | •  | •  |
| Analog 0-36V                | •  | •  | •  | •  | •  | •  | •  | •  |
| Frequency                   | •  | •  | •  | •  |    |    |    |    |
| PWM Duty Cycle              | •  | •  | •  | •  |    |    |    |    |
| Resistance                  | •  | •  | •  | •  |    |    |    |    |
| Current (0-20mA)            | •  | •  | •  | •  |    |    |    |    |
| Quadrature – X1             | •* | •* | •* | •* | •* | •* | •* | •* |
| Quadrature – X2             | •* | •* | •* | •* | •* | •* | •* | •* |
| Quadrature – X4             | •* | •* | •* | •* | •* | •* | •* | •* |
| Quadrature – B              |    | •  | •  | •  | •  | •  | •  | •  |

\*When configured as Quadrature, The next adjacent input is automatically configured as the channel B input. (i.e. If In1 = QuadX\_, then In2 = Quad Channel B)

| Output Type             | #1 | #2 | #3 | #4 | #5 | #6 | #7 | #8 |
|-------------------------|----|----|----|----|----|----|----|----|
| 00 - Disabled           | •  | •  | •  | •  | •  | •  | •  | •  |
| 01 – Active HI Digital  | •  | •  | •  | •  | •  | •  | •  | •  |
| 02 – Active LO Digital  | •  | •  | •  | •  | •  | •  | •  | •  |
| 03 – HS PWM Closed Loop | •  | •  | •  | •  | •  | •  | •  | •  |
| 04 – HS PWM Open Loop   | •  | •  | •  | •  | •  | •  | •  | •  |
| 03 – LS PWM Closed Loop | •  | •  | •  | •  | •  | •  | •  | •  |
| 04 – LS PWM Open Loop   | •  | •  | •  | •  | •  | •  | •  | •  |

| In/Out Tolerances (@25C) |         |
|--------------------------|---------|
| Analog Input             | +/-50mV |
| Resistance Input         | +/-2%   |
| Current Input (0-20mA)   | +/-50uA |
| Current Control Output   | +/-50mA |

UNLESS OTHERWISE SPECIFIED, DIMENSIONS ARE IN INCHES AND TOLERANCES ARE

| TWO PLACE DECIMAL | THREE PLACE DECIMAL | ANGLES |
|-------------------|---------------------|--------|
| +/- 0.05          | +/- 0.020           | +/-    |

DO NOT SCALE DRAWING

|                    |                 |
|--------------------|-----------------|
| CHECKED J. COOPER  | DATE 06/30/2023 |
| APPROVED J. COOPER | DATE 06/30/2023 |

|   |                                 |                  |                 |
|---|---------------------------------|------------------|-----------------|
| <b>MARLIN</b> TECHNOLOGIES INC.                         |                                 |                  |                 |
| TITLE<br>OUTLINE, 505040<br>MFLEX HIGH CURRENT 8IN/8OUT |                                 |                  |                 |
| SIZE<br><b>B</b>  | DRAWING NUMBER<br><b>014162</b> | TYPE<br><b>O</b> | REV<br><b>A</b> |
| DRAWN M. PETZKE   |                                 | DATE 06/21/22    | SHEET 3 OF 3    |

THE INFORMATION CONTAINED ON THIS DRAWING IS PROPRIETARY AND CONFIDENTIAL TO MARLIN TECHNOLOGIES INC. UNAUTHORIZED USE OR DISTRIBUTION WITHOUT CONSENT IS PROHIBITED.